

Model 1685
Multi-Carrier Signal Generator
Operation Manual



Revision	2.4
Date	27 October 2016

Table of Contents

1 INTRODUCTION.....	3
1.1 Symbols Used.....	3
1.2 Safety Instructions.....	3
2 OPERATING INSTRUCTIONS.....	4
2.1 Front Panel	4
2.2 Rear Panel	4
2.3 AC Operation	5
2.4 Operating Conditions	5
2.5 Water Ingress and Mounting.....	5
3 SYSTEM CARRIER-TO-NOISE MEASUREMENT.....	7
4 SERVICING INSTRUCTIONS	8
5 SPECIFICATIONS.....	8

1 INTRODUCTION

The Model 1685 generates RF continuous wave signals for use as reference signals when aligning a CATV forward band. This rack-mount unit may be configured with one to eight RF carriers. Each carrier may be activated individually or simultaneously. The optional built-in attenuator provides up to 70 dB of carrier amplitude range. With spectral purity of at least 60 dBc, the carriers may also be used for hum and noise evaluation tests.

1.1 Symbols Used

The following symbols are used in this manual and/or marked on the instrument.



Hazardous areas on the instrument are marked with this symbol. Consult this manual to learn the nature of the hazard and proper actions for safe operation.



Indicates an earth ground terminal



Indicates possibility of electric shock



Indicates a protective conductor terminal

1.2 Safety Instructions

- Read and follow all instructions in this manual.
- Risk of electrical shock exists if the unit is opened when AC is connected.
- Cleaning: Unplug and turn unit off before cleaning. Clean with a dry cloth only.
- Use only the cord supplied with the unit or an equivalent cord rated for at least 1 Amp and containing a protective earth ground conductor.
- Servicing should be done by qualified service technicians only.
- Use of the instrument in a manner not consistent with the instructions in this manual may impair the safety features and lead to damage or injury.

2 OPERATING INSTRUCTIONS

This section provides the instructions and information necessary to connect and operate the Model 1685 Multi-Carrier Signal Generator. Included are the identification and function of controls, connectors, and indicators. Before turning on the instrument become familiar with the functional components of the unit.

2.1 Front Panel

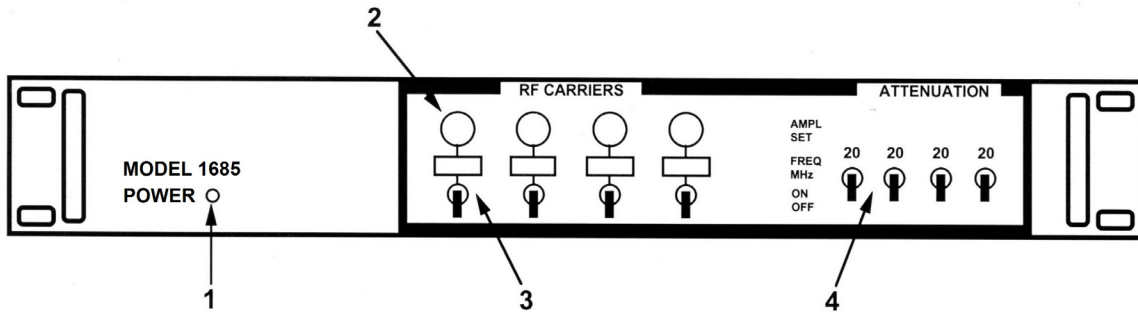

1. Power on indicator LED - LED illuminates when AC power is applied.
2. Ampl Set - Individual carrier amplitude adjustments controls. Each control allows adjustment of at least 13 dB to the associated carrier.
3. Carrier On-Off toggle switches - On - Off controls for individual carriers.
4. Output level attenuator toggle switches - switches allow output level attenuation of all carriers from 0 dB to 70dB in 10 or 20 dB steps.

2.2 Rear Panel



1. RF OUT - Female RF output F-connector. Connect to the cable system being tested. This port includes a blocking capacitor which will block DC or AC voltage up to 200 Volts. Higher voltages will damage the instrument.
2. A.C. Cord Attachment – 100-240V 50-60 Hz power attachment receptacle
 - a) Type IEC 60320-1 C-13
 - b) One amp cord rating (typical operating current <100 mAmps)

2.3 AC Operation



When operating the instrument from AC power, adhere to these rules:

1. Warning: The appliance coupler is used as the disconnect device. Do not position the instrument so that it is difficult to operate the appliance coupler.
2. Use only the cord supplied with the unit or an equivalent cord rated for at least 1 Amp and containing a protective earth ground conductor.
3. Warning: The AC plug shall be connected to a mains socket outlet with a protective earthing connection.

2.4 Operating Conditions

This instrument is intended for use under the following environmental conditions. Use outside of these conditions may result in safety hazards, incorrect operation, or damage.

1. Indoor use
2. Altitude ≤ 2000 meters
3. Ambient temperature $0\text{ }^{\circ}\text{C}$ to $50\text{ }^{\circ}\text{C}$
4. Relative humidity $<80\%$ up to $31\text{ }^{\circ}\text{C}$, $<50\%$ at $40\text{ }^{\circ}\text{C}$
5. AC voltage $\pm 10\%$ of nominal (some temporary over-voltage tolerated)
6. Transient voltage spikes $<2500\text{ Vp}$
7. Pollution degree 2 or less, non-conductive pollution

2.5 Water Ingress and Mounting

Do not set up or use unit where liquids or other conductive materials are used. Ensure that no liquids are spilled into the unit.

If water or other conductive material enters the enclosure, immediately turn off the unit and unplug it. Contact a qualified technician or return the unit to Applied Instruments for repair.

3 SYSTEM CARRIER-TO-NOISE MEASUREMENT

Carrier-to-noise ratio is a measurement of a carrier amplitude relative to the noise floor of the transmission system. This noise floor is created by the summation of natural thermal noise (-59.75 dBmV @25°C. in a 4 MHz BW) and the noise figure of each active device. Since all the inbound amplifiers "funnel" into the headend, the return portion of a two-way system is the main contribution to the noise floor. This is especially true in block translated systems where a portion of the inbound noise is converted, along with the desired carrier, to the outbound leg.

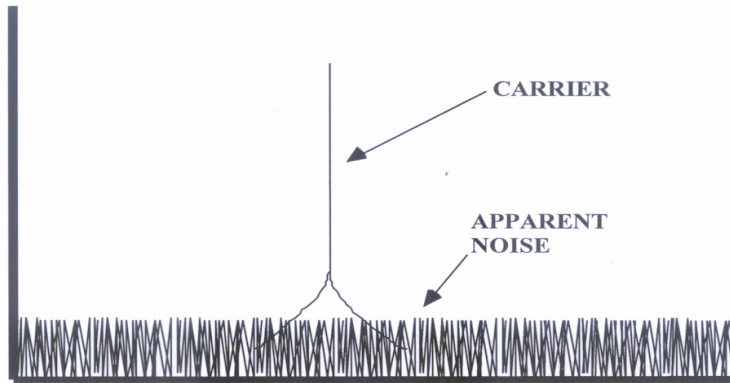

Fig.1: Carrier-to-noise

Figure 1 is a display of a carrier surrounded by broadband noise. The apparent noise level is usually a function of the resolution bandwidth and noise figure of the test receiver. To evaluate the carrier-to-noise ratio, insert a test carrier at the point of origin and adjust to system amplitude.

NOTE: If the test carrier is not at system level, record the difference in dB and add this quantity to the final reading.

Now connect a spectrum analyzer or signal level meter to the system test point.

NOTE: For tap levels below +15 dBmV, the receiver may require pre-amplification to assure "sample noise" levels are significantly above the receiver noise floor.

Tune the receiver to the test carrier frequency and record the level in dBmV. Next, remove the test carrier or tune the receiver about 2 MHz off center frequency. Remove attenuation as needed and assure that the noise level changes 1dB per dB of attenuator change. Read the level of noise and apply bandwidth and other noise correction as described in the receiver manual. Record this level. To obtain the system carrier to noise relationship, subtract the corrected noise level from the recorded signal level of the test carrier. If the test carrier was inserted at a level lower than system level, add this difference to the resultant. Repeat the above process at other frequencies in the spectrum.

4 Service Instructions

All service should be performed by a qualified technician only.



WARNING: Risk of shock is present when the cover is removed and AC power is present. Be sure to disconnect from AC before opening unit.

5 SPECIFICATIONS

Frequency

Frequency Range 5-1200 MHz
 Frequency Accuracy $\geq 0.01\%$

Output

Attenuator 0-70 dB in 10 or 20 dB steps
 Individual Amplitude Adjustment 0-13 dB
 Amplitude Stability + 0.5 dB/setting
 Residual Hum $< 0.1\%$
 Output Impedance 75 Ohm
 Spectral Purity (spurious & harmonic) ≥ 60 dBc

Max output level per carrier (dBmV)	Frequency (MHz)		
	5-860	861-1000	1001-1200
For hardware configurations up to 2 carriers.....	+59	+57	+55
For hardware configurations up to 4 carriers.....	+55	+53	+51
For hardware configurations up to 6 carriers.....	+52	+50	+48
For hardware configurations up to 8 carriers.....	+50	+48	+46

Mechanical

Operating Temperature Range 0-50 Degrees Celsius
 Power AC 100-240VAC, 50-60 Hz
 Current Rating 0.2A/120V, 0.1A/240V
 Size 1.75" H. x 19.0"W. X 12.5"D.
 Weight 8.5 Pounds

Approvals



For testing report specifics, contact factory at info@appliedin.com

WARRANTY

The Applied Instruments Model 1685 is warranted against defects in materials and workmanship for a period of twelve months. Applied Instruments agrees to repair or replace any assembly or component found to be defective under normal use during this period. Our obligation under this warranty is limited solely to repairing the instrument proven to be defective within the scope of the warranty when returned to the factory. Transportation to the factory is to be prepaid by the customer. Authorization (RMA#) by Applied Instruments is required prior to shipment.

Applied Instruments assumes no liability for secondary charges or consequential damages and, in any event, Applied Instruments' liability for breach of warranty under any contract shall not exceed the purchase price of the instrument shipped, and against which a claim is made.

Any application recommendation made by Applied Instruments for the use of its products is based upon tests believed to be reliable, but Applied Instruments makes no guarantee of the results to be obtained. This warranty is in lieu of all other warranties, expressed or implied, and no representative or person is authorized to represent or assume for Applied Instruments any liability in connection with the sale of our products other than that set forth herein.

Applied Instruments, Inc
5230 Elmwood Avenue
Indianapolis, IN 46203 USA
<http://www.appliedin.com>

Tel: +1 (317) 782-4331
Tel (Toll-free within USA): (800) 244-2976
Fax: +1 (317) 786-9665
Email: info@appliedin.com